



pennsylvania

DEPARTMENT OF AGRICULTURE
DIVISION OF RIDES AND AMUSEMENTS

Department of Agriculture
Division of Rides and Amusements

WATER ATTRACTIONS STUDY MATERIAL
for Pennsylvania Restricted Inspector Certification

Page 2: Introduction by Joe Filoromo, Supervisor

Page 3-22: General Study Material

Page 23-30: Water Attractions

Page 31-32: Contact Info and Regulation Requirements

Page 33-36: Ride Approval Information

Page 37: Attraction Checklist

Pennsylvania Amusement Ride and Attraction Water Slide Inspector Study Guide

Dear Ride or Attraction Operator:

To prepare yourself for the Amusement Ride Inspector test, it will be helpful for you to become familiar with the following study guide. This study material has been compiled to help the applicant prepare for the Certified Amusement Ride Safety Inspector Test. This document does not include all information required to answer all the questions on the test. The information in this document covers the essential areas of Amusement Ride inspections and should be helpful in preparing to become a certified inspector as well as for the test.

Regulations - It is also essential that all inspectors are aware of the regulations and review them regularly. Be sure to review the regulations found at this link:

https://www.agriculture.pa.gov/consumer_protection/amusement%20rides/Documents/AMUSEMENT%20RIDE%20REGULATIONS%20-%207%20Pa%20Code%20Ch%20139.pdf

Seminar - You are required to attend an approved seminar at least once within each three-year certification period. Your required hours of training for Water Attraction certification is 16 hours. The seminar alone does not prepare you for the test. If you need to become certified and have not yet attended the required seminar, we may extend a one-time grace period until the next seminar so that you can comply immediately pending review of qualifications.

Test Application- An application to become a Pennsylvania Qualified Amusement Ride Inspector is at this link: https://www.agriculture.pa.gov/consumer_protection/amusement%20rides/Documents/Inspector%20Application%202020%20fillable.pdf Please complete the application and return it to this office as soon as possible for review in order to schedule a test at an approved seminar or regionally.

The Amusement Ride Inspector test is administered by appointment throughout the year and during approved ride inspector safety seminars. If you wish to take the test, please contact Supervisor Joe Filoromo at 717-215-4316 or jfiloromo@pa.gov for any additional assistance.

The Department can and will change and up-date this material as necessary. The Department reserves the right to limit the number of times an unsuccessful person can attempt to pass the test to three (3).

The Department assesses a \$50.00 certification fee, payable the day of the test. Make checks payable to "Commonwealth of Pa". The Department cannot accept cash.

Questions should be submitted to jfiloromo@pa.gov or 717-215-4316.

Thank You,

Joseph G. Filoromo, Supervisor

General Study Material

It is the intent of this study material to help the reader become a more valuable member of the amusement industry. It is anticipated that the reader intends to become a Certified Amusement Ride Inspector empowered to operate within the Commonwealth of Pennsylvania. Therefore, it is important for the reader to understand that the ability to become a Certified Ride Inspector rests on a combination of experience, mechanical aptitude, and testing ability. Because of the requirement for experience, **NOT ALL THE QUESTIONS ASKED IN THE CERIFICATION TEST ARE FOUND IN THIS STUDY MATERIAL.**

RESPONSIBILITY OF THE CERTIFIED RIDE INSPECTOR

It is **critical** to remember that the inspector who signs the inspection affidavit is the person **responsible** for the information found on that report.

Each inspector is responsible to provide a signed inspection affidavit for the inspection of **all** of the rides he/she inspects.

Inspections conducted by a **team** of inspectors require that each team member submit an inspection affidavit for rides he/she inspected.

Multiple signers of an inspection affidavit will **void** the document; and require an appropriate inspection by an explanation to the Department of Agriculture.

HISTORY OF THE ACT

In 1984 the Pennsylvania Legislature enacted, and Governor Thornburg signed into law legislation “providing for the inspection of amusement rides and attractions; granting powers and imposing duties on the Department of Agriculture; creating the Amusement Ride Safety Advisory Board; and imposing civil and criminal penalties”. This (Act 1984-81) is known as “The Amusement Ride Inspection Act”.

This Act empowers the Department of Agriculture to develop and enforce regulations found in 7 Pa. Code, Chapter 139. It is the Act and the accompanying regulations that will dictate the actions of Certified Amusement Ride Inspectors.

GUIDELINES FOR RIDE INSPECITON

LOCATION AND INSTALLATION:

1. Free From Adjacent hazards and Interferences:

All rides, walk through shows, and funhouses, should be located in such a manner that they do not physically interfere with other rides. Severe and even fatal accidents have occurred as a result of improperly placed rides.

Operating clearances should be carefully verified for each ride prior to passenger loading. Nearby utility poles, trees, buildings, and other structures may present interference to safe ride operation and their clearances should be verified. There shall be a six-foot clearance between rides. Particular attention should be paid to overhanging items such as lighting, power lines, telephone cables, overhead piping, guy wires, and anything which is apt to be a hazard to the safe operation of the ride. It should be noted, that power lines may increase their sag under conditions of hot weather and heavy current draw (after the initial inspection). Be sure to take this possibility into account when inspections are made.

Rides and fencing should be so located that it is impossible for a person to reach over the fence and grab the hand of a passenger reaching out of a carrier.

2. In Level Position on Solid Ground or Pavement:

Portable rides are intended for installation on solid ground or pavement. They are designed in such a manner that no special foundations are required. Many of them are trailer mounted and have outrigger supports to provide stability and to resist wind forces. Some have hydraulic or mechanical jacks to assist in installation and leveling. Some will require blocking to produce a satisfactory installation.

Assuming that the soil or pavement is adequate to provide ride support, it is desirable that the ride be approximately level after all adjustments are made. This can usually be done by sighting the ride from several directions.

A small hand level can be used to arrive at a more accurate determination. In general, the taller the ride the more need for accurate leveling.

3. Properly Blocked and Jacked:

Every ride installation should be examined to determine that the blocking or jacks, which have been used, are doing their job and not presenting a hazard in themselves. Narrow blocking should be avoided since the blocking should spread the load over a larger area and not concentrate it. Excessively high blocking contributes to instability. Poorly placed blocking can contribute to instability and should not be permitted. Blocking should be placed at the points which the manufacturer has indicated as being proper. In the absence of specific information, the blocking should be placed under the obvious strong points of the main frame or outriggers of the ride. Blocking generally should not be placed at locations where the structure may be observed to move or bend on the blocking as the ride operates. The structure and blocking should be checked to assure that the structure is resting firmly on the blocking and that a suitable number of blocks have been used to properly support the ride structure.

If the ride is equipped with mechanical or hydraulic jacks, the inspection is simplified. The jacks should be examined to make sure that they are in good mechanical condition and being used properly. Check for missing parts such as the base plate on the end of the Jack screw or cylinder. If the original plate is missing and another plate or wood block has been substituted, make sure it is of adequate size to properly spread the load (as the original one did). It should be noted that hydraulic pressure can increase in the jack due to expansion when the jack is exposed to heat and direct sun rays. This increased pressure can cause the leveling jack to raise the ride off the locking rings or support and create an unstable condition. This condition can be avoided if the needle valves and hand pump valve are opened to relieve pressure on the leveling jacks after the ride is leveled and otherwise supported. Whether the ride has been blocked, jacked, or a combination of the two achieve level conditions, the important thing is to be sure that the ride is not only level, but also supported securely on the blocks or jacks.

In all cases, the ride structure, and the blocks or jacks, should finally be examined when the ride is running. This is in order to be sure the support is proper, and nothing has been overlooked. On some rides, the rides frame tends to move relative to the blocking during the ride operation. For this reason, the ride should be examined periodically during its operation to assure it does not move off the blocking. Blocking shall have the same width, length, and height. (e.g. Four-Foot-high requires 4' X 4' base)

4. Properly Anchored, Braced and Guyed:

If a ride requires anchors, braces, or guy lines to produce a satisfactory installation, they should be properly installed before the ride is permitted to operate. Items such as the inflatable plastic pillows, (i.e., Moonwalk, etc.), need to be anchored securely in position as they tend to move around rather easily in operation. Stakes are commonly used in conjunction with lines from the pillow in a manner like staking a tent. In this situation, the installation should be examined to make sure that a sufficient number of stakes have been properly installed to secure the item in position. The stakes, particularly near the entrance, should not be installed in such a manner as to present a stumbling or tripping hazard. On hard pavements where it is difficult to drive stakes, concrete anchors (similar to boat anchors) or sandbags are sometimes used. These can be effective and should be permitted if they are of adequate weight and appear to satisfactorily restrain the pillow.

Leveling and blocking (portable models)

1. Inspect leveling and blocking at each set up and at the start of each day (rides erected in soft locations require more frequent inspection).

2. Inspect for proper cross blocking or crib blocking. Cross blocking distributes weight evenly.

*Always cross block
Cross blocking distributes weight evenly.*

*Recommended blocking:
3 X 12 X 36" and 3 X 12 X 24"
unless otherwise noted.*

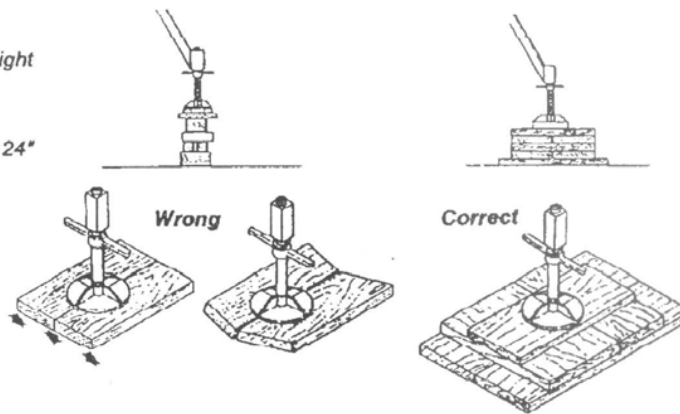

To avoid crushing under load "crib" blocking should be spaced no more than 1/4" for drainage.

*"Crib" blocking
Large voids can let blocking crush under load. 1/4" spaces allow adequate drainage.*

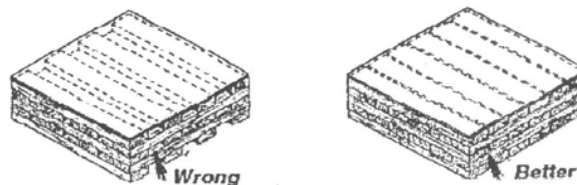

3. Inspect blocking for proper contact with ground

4. Level ground under blocking by digging where possible, instead of filling. Fill dirt will be soft and allow settling.

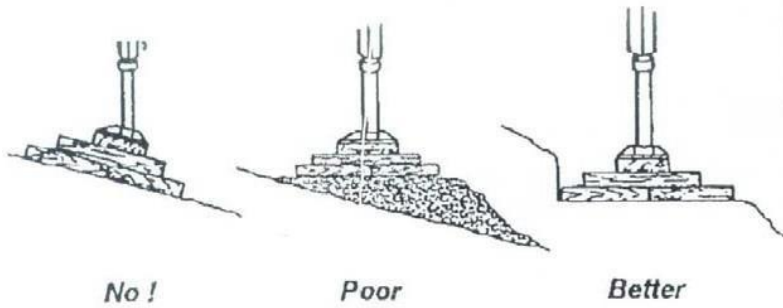

Blocking on a slope
 Level the ground beneath blocking by digging where possible. Don't fill, the fill dirt will be soft allowing the ride to tilt

5. Inspect hydraulic leveling jacks for leaks at every set-up. The hydraulic jacks are for leveling purposes only. They must be retracted and their shut-off valves closed during normal ride operation. Likewise, they must be fully retracted and their shut-off valves closed before transporting the ride.

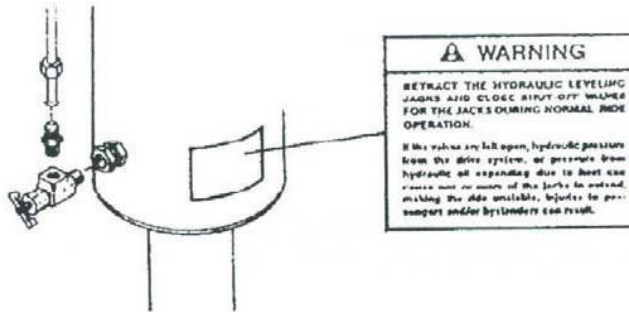

6. Check the lock rings on all screw jacks for tightness.

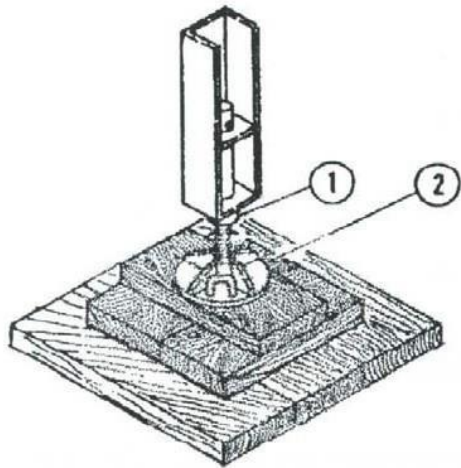

1. Screw jack
 2. Lock ring

Bracing of a demountable nature is often used both on the ride structure and to support scenery panels. This bracing should be checked to verify it is present, installed at the proper locations, and adequately secured. A thorough visual examination of the ride will usually enable one to spot missing braces. Clues to look to for are holes not filled with bolts or pins. These may be intended as attachment points for braces. **In case of doubt, refer to the manufacturer's manual for definite information.**

Some rides, particularly high structures, use guy wires or cables to prevent collapse from wind loads or to tie various parts of the ride structure together more or less rigidly. Guy wires and wind braces, where necessary, should be properly placed, properly adjusted, and in good condition in order to accomplish their job. Connection points of all guy wires should be examined to be sure they are of good quality. If the connection is made to a stake in the ground, be sure that the stake is suitable anchored in the ground (or pavement) so it does not yield and allow the guy wire to develop excessive slack. Guy wires, many times, occur in pairs and when properly adjusted, will have nearly equal tension in both wires of the pair. If the wires are not properly adjusted, excessive movement of the ride may occur. The manufacturer's manual is a good reference to determine the number, placement and adjustment of the guy wires or cables.

5. Stairs and Walkways in safe and Secure Condition:

Walkways should be solid and free of projections which might cause stumbling. Extremely smooth metal or wood surfaces can result from normal traffic wear. These can be conducive to falls and can be quite dangerous, particularly when wet. When these conditions are encountered, corrections should be made before operation is permitted. Handrails should be present on stairs and ramps. Walkways may or may not need handrails depending on the physical layout. The judgement and discretion of the inspector will be required in some cases to assess the degree of hazard involved and the correction to be made. Bear in mind that public safety is paramount. On rides where the public enters or exits above grade, the stairs, ramps, and walkways should be checked to be sure they are in good condition.

6. Proper Fencing and Railings

All rides must be adequately fenced to provide protection to spectators and riders. Fences should be located to provide a safe distance from the outmost point of swings or aerial rides.

Breaks in fencing be limited to those necessary to allow proper entrance and exit by passengers. Slides, or their walkways, should be protected by guards to restrain the person sliding from falling over the side. Power units should be shielded from the public. In some cases, this will require fencing. Depending upon the construction of the power unit, however, some units can be shielded by barricades or screen panels at the openings of the trailer containing the power unit. **The inspector should use his judgement to determine that a proper result is being obtained.**

7. Fire Extinguishers- Number, Size & Locations:

The Inspector should verify that a properly charged fire extinguisher is present on every site and that the operator knows its location. All extinguishers should meet the standards of state and local fire officials.

8. Free of Unguarded Pinch Points:

Rides and shows should be carefully examined for areas where a person might be struck by, caught in, caught between, or otherwise exposed to moving parts or hazards. Be alert to the possibility that children and even adults sometimes do unexpected things and thereby risk their own safety.

STRUCTURAL INTEGRITY:

9. Assembled in Correct Manner:

A ride, when completely assembled, should be examined to determine if it has been put together properly. Previous experience and the manufacturer's manual will be of value in making this determination. Gross mis-assembled will be rather obvious by comparing the assembled ride with photos or drawings in the manual.

Some mis-assembly will be less obvious, such as a member being bolted to the wrong place or attached to the wrong side of another member.

Sometimes this can be determined by an examination of photos or sketches and sometimes it "**Just doesn't look right**". Any sign or clue of improper assembly should be reason not to allow the ride to operate until the correctness of the assembly has been determined. In case of doubt, contact the inspection office. The essence of correct assembly is the use of proper components in the right places. Be alert to areas which have been modified from the manufactured configuration. Mechanical items which you know or suspect to be different from the original item should be checked to determine if they appear adequate for the job. They should also be looked at from the standpoint of their effect upon the characteristic of the ride such as speed, control, braking, etc. If the substituted item has deteriorated the quality and safety of the ride, then its use should not be permitted.

10. Free of Cracks and Excessive Wear:

Most manufacturer's service manuals and bulletins will indicate the areas where heavy stresses occur and where cracks are prone to develop. The bulletins usually pinpoint specific areas where problems have been found and indicate the corrective action necessary. In some cases, modification kits are required to correct the problem. In other cases, instructions are given for making repairs on the existing members. It should be remembered information is not exhaustive and cracks or other problems may develop in areas for which there is no information available. If the repair is to be made by welding, it should be done by a welder skilled in this type of repair. If cracks are welded cracks structural members which show evidence of abuse, extensive welding, or widespread cracking should be recommended for further repair. Poor quality welds can many times be detected by their appearance. In case of doubt, do not permit a ride with evidence of poor welding to operate until satisfactory correction has been made. In some cases, the manufacturer will indicate that a particular member is not to be repaired by welding. Any cases of this nature should be cause not to allow the ride to operate no matter how good the weld may appear to be. **Insist that**

the repair be made in accordance with the manufacturer's specifications.

Cracked paint may or may not indicate a cracked area. It is a good clue, however, and all such locations should be examined carefully. The areas around bolt and pin holes should be examined for cracks. Pins and bolts in critical areas should also be checked for evidence of cracks, particularly in the threaded portions, around cotter or pin holes and under the head. In case of doubt, have the bolt or pin replaced before operation.

During the examinations of the structure for cracks, the inspector should look for loosened bolts or rivets and badly worn or elongated holes. Pinned connections or other joints that have developed excessive wear should be recommended for repairs in accordance with manufacturer's specifications.

11. Properly Pinned With Correct Grade of Bolts:

Ride manufacturers use bolts throughout their products. Many in locations where failure could be catastrophic with injury or death resulting. Inspectors and others, concerned with ride safety, need to familiarize themselves with the various types and grades of bolts used by the ride industry. Identification of bolts that are in place on a structure should be of particular concern to inspectors and ride maintenance personnel. Rides built by European manufacturers will contain graded metric bolts. The inspector should check for loose bolts and verify that common bolts have not been substituted for graded bolts. Particular attention should be given to the main ride structure, sweep connections, tub and car attachments, and nay connection where bolt failure could be catastrophic.

12. Properly Pinned Secured with Retainers:

As an aid to rapid assembly and disassembly, many ride connections are made with pull pins rather than bolts. The type of pin used is designed to be used with a spring pin ("R" pin or other type) as a retainer to prevent the pull pin from working out as the ride operates. These pins have strength qualities similar to graded bolts. The inspector should make sure that any pins which have developed cracks should be replaced. Spring retaining pins, ("R" pins), which have spread to the point that they are no longer held securely in position, should also be replaced.

13. Properly Aligned Including Sheaves and Cables:

A ride should be inspected for alignment of major parts such as uprights, wheels, bearings, sheaves, guides, couplings, cables, gearing, shafting and

other mechanical parts or assemblies. Most out of line conditions can be determined by visual inspection. In case of doubt, contact the inspection office.

14. Cables, Chains, Belts and Gearing in Safe Condition:

All wire rope, whether used for support or drive cables or for any other purpose, must be thoroughly examined. Wire rope found to be damaged is to be repaired or replaced with new rope of proper design and capacity, in accordance with the ride manufacturer's specifications. Any of the following conditions is cause for rope replacement or repair:

- A. In running ropes, six randomly distributed wires in one rope lay, or three broken wires in one strand in one rope lay. A rope lay is the length along the rope in which one strand makes a complete revolution around the rope.
- B. In pendants or standing ropes (ropes bearing the entire load and subjected to constant pressure and surge shocks), evidence of more than one broken wire in one rope lay.
- C. Heat damage including welding, brazing and soldering to the rope itself.
- D. Improper use of Clamps and Excessive Splicing:

All mechanical devices that brake, control, or come in contact with wire rope, such as rollers, drums and sheaves must be examined for broken chips, undue roughness, uneven or extreme wear.

Chains, belts, gearing and other drive components should be checked to make sure that they are in satisfactory operating condition and show evidence of proper lubrication.

Support chains such as those used to support chair seats on swings should be examined to make sure they are in good condition and are attached safely. Extreme wear, cracked or broken links or attachments, call for immediate replacement. It is recommended that chain be welded link and of proper capacity; and any components shall be of compatible material. Check with Manufacturer for proper type of chain.

LOCK-OUT / TAG-OUT

Whenever it becomes necessary to work on belting or any piece of machinery, employees shall assure themselves that a proper tag is attached to the pump, governor, valve throttle, switch, or other device used to set the machine into motion.

The equipment shall be de-energized and locked out. Each employee should be assigned one 6 hole "scissors-type" lock-out assembly, two personal padlocks (for which only the employee will have keys) and two plastic "Danger-do Not Operate" tags to be used in conjunction with the padlocks and lock-out device.

These lock-out tools must be carried by the employee to the job site at all times, and be properly installed before any work is performed on electrical or mechanical equipment whenever there is the possibility of electrical shock, or of the possibility of machinery being set in motion while work is being performed.

Each person working on the job must install a padlock and tag identified and employees name on the lock-out device before beginning to work and should remove the personalized lock and tag when leaving the job site.

If the machinery does not have a safety switch or does not have a switch that can be locked off, notify the electrical department prior to beginning work.

The electrical crew will remove fuses or disconnect wires in order to make the job safe to perform the work.

Red tagging where fuses are removed or wires disconnected must be done by the electrician and only the electrician can restore power by making the necessary connections.

Locking a push-button station stop button "off" shall not be considered as safety locked off, because a problem with the wiring or someone tampering with the motor starter could energize the equipment.

In a case where a circuit breaker is the only disconnecting means, in lieu of disconnecting wires, a "Do Not Operate" tag may be securely attached to the turned off breaker and a guard posted to assure that no one turns the circuit on.

No one may, at any time remove any other persons locking device, or start up any equipment while anyone else has it locked out.

LOCK-OUT PROCEDURES:

To assure the safety of maintenance working on or about any large piece of equipment such as an amusement ride/attraction or device, lock-out procedures should be developed and implemented.

The following is an example of a typical maintenance lock-out procedure.

(Example:)

Lock-out procedure Ride/Attraction:

The main key switch of the control power must be locked in the off position and the key removed to avoid any accidental start-up of the device while personnel are working on it.

A red tag must be affixed to the emergency stop button before any maintenance work can be carried out on the ride or attraction.

Maintenance:

Employees working about moving machinery or live equipment and circuits shall proceed with great care when performing their work, considering carefully each act and doing nothing which may endanger themselves or others.

Employees shall be careful to place themselves in a safe and secure position and to avoid slipping, stumbling or moving backward into moving machinery or live parts, or into openings.

Note:

It is recommended that all power and operating machinery be locked off prior to any work being started, however where live electrical circuits and operating machinery is necessary to perform required work, a minimum of two (2) qualified persons should be required in these locations maintaining radio, or telephone communications to the ride/attraction control operator.

IDENTIFICATION OF FASTENER GRADES

Virtually every mechanical assembly used by industry, transportation and construction is literally held together with fasteners.

Few of us realize how important the quality of these fasteners is in assuring that the equipment we depend on daily is safe and reliable.

Before a mechanic can select the correct grade of fastener for the application and determine the proper installation torque, he must know the strength of each grade and be able to tell one from the other. This becomes vitally important when a mechanic removes an OEM specified bolt from a connection to perform regular maintenance. The mechanic must identify the grade of fastener removed and replace that bolt with the SAME grade.

Failure to do so could result in an accident because of a lesser grade bolt used in the connection. This may cause expensive property damage and/or sever personal injury. Extensive liability suits could result.

Four nationally recognized technical groups of engineers define fastener standards and specifications. These organizations are the Society of Automotive Engineers (SAE), the American Society for Testing and Materials (ASTM), the International Standards Organization (ISO), and the Industrial Fastener Institute (IFI). They have established a method of identifying various grades of fasteners. They also established the minimum strength requirements, chemical analysis of steel to be used and, where called for, the degree of heat treatment that is permissible for each grade. The following chart shows the head markings in use, and the material and mechanical requirements for each SAE grade.

Besides the standard grad markings on the heads of the fasteners, as indicated in the Head Marking Chart, most fasteners manufactured in North America have a manufacturer's identification logo placed somewhere on the product.

A listing of these logos is found in the IFI-122 publication issued by the Industrial Fasteners Institute, Cleveland, Ohio. The purpose is for identity and traceability. These fasteners MUST meet the indicated SAE specifications. If, for instance, there are just three radial lines on the head, indicating it to be Grade 5, with other markings, then the bolt is imported. This is very important because U.S. laws do not apply in foreign countries. We are not to say that imported fasteners without a manufacturer I.D. do not meet SAE specifications...they just don't HAVE to meet them; and there is no incoming inspection made of imported fasteners by the brokerage firms that import and distribute them.

The Bowman Distribution Engineering Department has tested imported bolts marked with Grad 8 radial lines that did not meet Grade 5 specifications; yet others out of the same box, identical in appearance, would meet the required specifications. The point is, with imported bolts, you must know WHAT you are buying.

Imported fasteners are purchased by brokers who buy from many different sources. In the case of a liability claim, if there isn't a manufacturer's I.D., there is absolutely NO WAY to trace the manufacturer of the bolt.

The chart in this book lists the different SAE and Metric grades of fasteners.











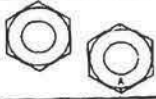





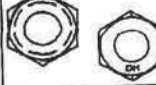

With the trend of downsizing in the automotive industry and the increasing use of metrics, original equipment manufacturers could not rely upon the strength of the Property Class 8.8. Instead, they have automatically upgraded themselves with an increase in strength by specifying the 9.8 Property Class.

Although some Grade 6 fasteners (formally discontinued by SAE in 1964), or those marked with only four radial lines, may have tensile strengths which are close to or compare to those of the Grade 8, NEVER substitute a Grade 6 for the Grade 8. They will not meet the SAE Grade 8 steel chemistry requirements. Where an SAE Grade 8 cap screw is specified, or designated as OEM, ALWAYS make replacements with the SAME grade to prevent liability claims. Consult your service manuals or factory representative for verification.



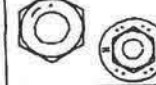







Glossary of Terms

ASTM	American Society for Testing Materials (Chemical & Physical Specifications)
ANSI	American National Standards Institute (Dimensional Specifications)
SAE	Society of Automotive Engineers Specification of Grade 5 and Grade 8 Hardware
ASME	American Society of Mechanical Engineers
ISO	International Organization for Standards
FQA	Fastener Quality Act (Public Law 101-592) To be enacted May 27, 1998

BASIC FASTENERS

Product Grade Identification	Industry Standards	Material	Nominal Product Diameters	Tensile Strength PSI	Product Hardness Rockwell	Marking Requirement For Matching Nut
	SAE J429 Grade 1	1010 - 1020 Low Carbon Steel	1/4 thru 1 1/2 and bolts longer than 6"	60,000	B70 - B100	
	SAE J429 Grade 2	1018 - 1020 Low Carbon Steel	1/4 thru 3/4 over 3/4 to 1 1/2	74,000 60,000	B80 - B100 B70 - B100	
	ISO R898 Property Class 5.8 SAE J1199	Low or Medium Carbon Steel, cold worked	M5 thru M24	75,400 (520 MPa)	B82 - B95	
	ASTM A449 Type 1 SAE J429 Grade 5	1035-1038 Medium Carbon Steel, heat treated	1/4 thru 1	120,000	C25 - C34	
			Over 1 thru 1 1/2	105,000	C19 - C30	
	ISO R898 Property Class 8.8 SAE J1199	1035-1038 Medium Carbon Steel, heat treated	M4 thru M16	116,000 (800 MPa)	C20 - C30	
			M17 thru M36	120,350 (830 MPa)	C23 - C34	
	ASTM A193 B - 7	4140-4145H Chromium-Molybdenum Alloy Steel	Threaded Rod and Studs 2 1/2 and Under	125,000	—	
	SAE J429 Grade 8	Carbon steel	1/4 thru 3/4	150,000	C33 - C39	
		15-11 Carbon Steel	7/16 and Smaller			
		Medium Carbon alloy	other sizes			
	ASTM A354 Grade BD	Special Alloy Steel, oil Quenched & Tempered	1/4 thru 1 1/2	150,000	C33 - C39	
	SAE J429 Grade 8.2 SAE J1199	Low Carbon Boron Martensite Steel, Quenched & Tempered, Limited Use	Hex and Flange 1/4 thru 1	150,000	C33 - C39	
	ISO R898 Property Class 10.9, ASTM F568	Medium Carbon Alloy Steel, oil Quenched & Tempered	M6 thru M36	150,800 (1040 MPa)	C33 - C39	
	Karalloy Special	Proprietary Fine Grained Alloy Steel, oil Quenched & Tempered	1/4 thru 1	180,000 - 200,000	C38 - C42	

BASIC FASTENERS

Product Grade Identification	Industry Standards	Material	Nominal Product Diameters	Tensile Strength PSI	Product Hardness Rockwell	Remarks
	ASTM A307 Grade A	1010 - 1020 Low Carbon Steel	1/4 thru 4	60,000 (414 MPa)	B69 - 100	Structural bolt dimensions, marked 307A
	ASTM A307 Grade B	1018 - 1020 Low Carbon Steel	1/4 thru 4	60,000 (414 - 690 MPa)	B69 - 95	Structural bolt dimensions, marked 307B
	ASTM F837 Group 1	Stainless Steel Type 304	.060 - .625	95,000	B80	May be marked; 304 or 304CW : Condition is cold worked (CW) marking on top or side
			.750 - 1.50	70,000	B74	
	ASTM F837M Property Class A1-50	Stainless Steel Type 304	M6 - M36	500 MPa	B70 - B95	Metric stainless socket head, may be marked A1-50, top or side markings
	ASTM F593C	Stainless Steel Type 304	1/4 thru 5/8	100,000	B95 min	Cold worked product, may be marked C or D for size; alternates 304 or UNS 30400
	ASTM F593D	Stainless Steel Type 304	3/4 thru 1 1/2	85,000	B80 min	
	ASTM F593G	Stainless Steel Type 316	1/4 thru 5/8	100,000	B95	Cold worked product, may be marked G or H for size; alternates 316 or UNS 31600
	ASTM F593H	Stainless Steel Type 316	3/4 thru 1 1/2	85,000	B80	
	ASTM F468	Silicon Bronze	1/4 thru 3/4	70 - 100,000	B75 - B95	May be marked F468K, C65100, 651; Metric standard is found in F467
			7/8 thru 1 1/2	55 - 90,000	B70 - B95	
	ASTM A325	Medium Carbon, Carbon Boron, or Medium Carbon Alloy Steel	1/2 thru 1	120,000	C25 - C34	Structural bolt dimensions; larger head, short thread length
			1 1/8 thru 1 1/2	105,000	C19 - C30	
	ASTM A490	Medium Carbon, Alloy Steel	1/2 thru 1 1/2	150,000	C33 - C38	Structural bolt dimensions; larger head, shorter thread length; NEVER coated.
	ASTM A574	4140-4145H Alloy Steel	1/4 thru 1/2	180,000	C39 - C45	Standard U.S. thread socket products are all same grade—no marking. Knurl pattern is Mfg. mark
			5/8 and larger	170,000	C37 - C45	
	ASTM A574M	Alloy Steel	M6 - M48	1200 MPa (174,000)	C38 - C44	Marking on top or side, knurl pattern is Mfg. I.D., ISO/DIN specifications include 8.8 and 10.9 classes

Inspection

Joint Inspection

Some joints will appear to wear rapidly on new rides. This is usually a result of the holes not aligning in the mating parts. When this condition occurs, it results in “point contact”. A joint with this condition will generally wear rapidly until the load is distributed evenly over the fastener and the parts.

If in doubt about the condition of a bolt, pin or hole on a new ride consult the manufacturer and replace as required.

1. Inspect stationary joints for “egg-shaped” wear and loose pines

1. Stationary joint wear
2. Stationary joint-misaligned holes resulting in point contact

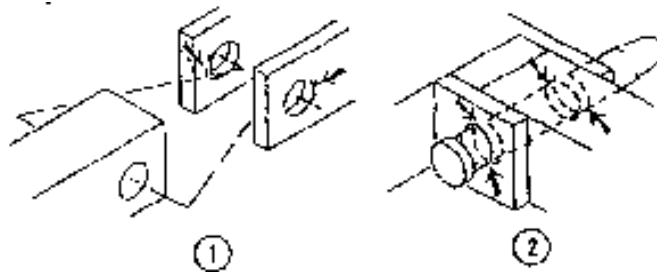

1. Severe corrosion
 - a. Rust appearing to stem from interior of cable.
 - b. Cable appears clean but previous corrosion is evident from pitted condition in wires.
2. Inspect moving joints for wear and lubrication.
3. Inspect welded structural joints for cracking or fatiguing.
4. Inspect bolted structural joints for cracking, fatiguing and proper bolt tightness.
5. Inspect pine and keepers on all pin joints for wear and proper installation.
6. Inspect all pins for proper manufacturer identification marks.

Cable Inspection

Replace cables if any of the following conditions exist. If more than one cable is used, cables must be replaced as a set.

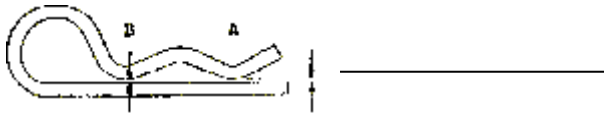

Acceptable hair pins
 Dimension "A" equal's
 dimension "B" in a relaxed
 position

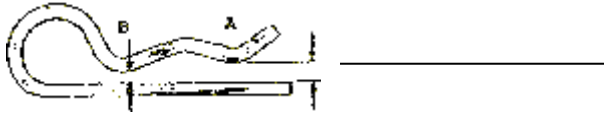

Unacceptable hair pins
 Dimension "A" is greater than
 dimension "B" in a relaxed
 position

**NEVER ATTEMPT TO BEND A HAIR PIN BACK INTO SHAPE
 REPLACE IT WITH A NEW PART.**

The correct installation of a hairpin is shown. Incorrectly installed
 hairpins are more likely to fall, and will distort after only a few users.

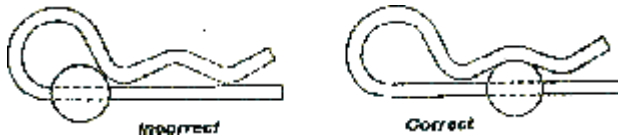

Recognize and recommend the safety procedures specified in ASTM
 Standards F770 Operation Procedures for Amusement Rides and
 Devices and F853 Maintenance Procedures for Amusement Rides
 and Devices.

FIRE SAFETY & FIRE EXTINGUISHERS

Fires have played a part in the amusement industry for many years. In the early 1900's fire destroyed many amusement piers and parks. In the mid-eighties, a devastating fire in New Jersey claimed the lives of 7 teenage park visitors while they were walking through a Haunted House type attraction made up of a series of trailers. Amusement ride regulations were implemented by a number of states, including Pennsylvania, following the fire in New Jersey.

Fire Safety and Fire Extinguishers play a part in the inspections, operations and maintenance of every fixed site and mobile amusement operation. Areas of concern in the amusement industry include such things as Walk through Attractions, Gas Powered Rides, Generators, Stock Trailers and Warehouses, electrical Equipment, Dark Rides, Flammable and Combustible Liquid Storage, as well many other attractions, amusement rides and devices to numerous to mention.

The National Fire Protection Association (NFPA) has classified four general types of fires, based on the combustible materials involved and the type of extinguisher needed to put them out. The four fire classifications are A,B,C and D. Each classification has a special symbol and color identification

General Classes of Fires

- Class A: This type of fire is the most common. The combustible materials are things such as wood, cloth, paper, rubber and plastics. The common extinguisher agent is water, but dry chemicals are also effective.
- Class B: Flammable liquids, gases and greases create class B fires. Extinguishers to use are foam, carbon dioxide and dry chemical.
- Class C: These fires are electrical fires and non-conducting agent must be used. Carbon dioxide and dry chemical extinguishers are to be used.
- Class D: Combustible metals fires such as magnesium, titanium and sodium.
- Class E: These fires require specialized techniques to extinguish them.

Types of Fire Extinguishers

Here is a list of fire extinguishers most commonly found in an amusement operation:

- Water
- Carbon Dioxide
- Dry Chemical
- Multipurpose Dry Chemical

Multipurpose fire extinguishers (ABC) will handle all A, B, and C fires. All fire extinguishers are labeled with either ABC, or A, or B or C, so be sure to read the labels.

How to Use a Fire Extinguisher

Even though extinguishers come in several shapes and sizes, they all operate in a similar manner. Here's an easy acronym for fire extinguisher use:

P A S S - Pull, Aim, Squeeze, Sweep

- | | |
|----------------|---|
| PULL | the pin at the top of the extinguisher that keeps the handle from being accidentally pressed. |
| AIM | the nozzle toward the base of the fire |
| SQUEEZE | stand approximately 8 feet away from the fire and squeeze the handle to discharge the extinguisher. If you release the handle, the discharge will stop. |
| SWEEP | the nozzle back and forth at the base of the fire. After the fire appears to be out, watch it carefully since it may re-ignite! |

Suggested Areas to Check during Fire Safety Inspections

- Trash and litter, no unnecessary accumulation
- Housekeeping, rides and work areas neat and clean
- Fire extinguishers, well-marked, correct types, charged and ready to go
- Hazardous Materials, stored in designated areas
- Exits, well-marked and unobstructed
- Wiring, good connections, good grounds, insulation intact
- Smoking, only in designated areas, signs posted
- Flammable materials, being handle with care, sign posted where applicable

**Please note, this is not an all-inclusive list. Inspectors are encouraged to develop their own list of inspection points.

Waterpark Attractions

Waterparks present a safety inspector with a major challenge to the effectiveness of their efforts because no two facilities or attractions are the same. A Scrambler is a Scrambler wherever it is operating but this is not true of Waterpark attractions. Circumstances assessed in one scenario may not be the same in a similar appearing arrangement in another facility. The inspector must be cautious to not generalize when attempting to set parameters for safety in these aquatic family recreation centers.

Waterpark inspections are further clouded because the attractions deal with few mechanical considerations such as blocking, ride assembly, NDT and other aspects which are normally part of a typical amusement ride. Couple this with the fact that, in most Waterpark attraction, the guest has a strong sense of and some real control over his or her experience and the inspection process gets even cloudier.

The key factor in Waterpark operations is an attentive staffing that is well trained and continuously doing their job. Industry practice is pretty consistent and clear in these areas and offers specific checkpoints for the inspector. The inspection of a Waterpark for hazards and exposure to injury demands the inspector pay close attention to staff procedures, behavior, training and conduct as well as the attractions themselves. An inspector should check to make sure that a documented training and operations program is on file and being implemented. A check of rescue equipment for condition and availability should be made.

Serpentine Slides

Slides of all types must be supervised at the point of dispatch. This does not mean that each flume needs to have an attendant, but the arrangement of the workstation and guest traffic control must assure that the attendant has full control of the guests to the point where they cannot enter the flume without direction or authorization.

There should be no significant water dripping from slide joints. If it looks like the situation has been ongoing, take a closer look at the structural conditions to see if there is obvious advanced stages of rust or scaling.

There should be no buckles or unaligned joints in the slide path and there should be no raw edges of fiberglass within reach of the guests. These often cannot be seen unless the inspector walks the slide which usually means being at the park prior to opening or after closing.

Head first sliding is generally not acceptable unless the slide is specifically designed for it. Multiple riders (2 or more) are also generally prohibited unless the slide is designed to accept this arrangement. At no time should riders be allowed to kneel or stand while riding the flume.

Speed Slides

Speed slides, for the most part, have straight slide paths, features flat bottoms and near vertical shallow flat sidewalls. These attractions will characteristically have short distances, vertical drops and high speeds. Most speed slides end in run out chutes or a combination of run out chute and catch pool. Safety on these attractions depends on the rider following specific instructions of the dispatch attendant with respect to riding posture and on clear communication between the top and bottom attendants regarding dispatch of riders.

Catch Pools

Catch pools can vary in size depending upon the attraction. Generally, the distance from the slide mouth to the opposite wall should be 20-25 feet. Water depth can vary as well depending upon the application, but 36 inches is generally a standard guide at the slide exit. The 36-inch minimum rule applies more clearly to slides which discharge the rider more than 2 inches above the catch pool surface.

Staff should not permit guests to linger or play in the catch pool. Where the slide discharges into a conventional swimming pool, there must be a clearly marked catch area and permits no general play or swimming in the area. In these installations, the catch area should be monitored by a dedicated guard.

Slow Rivers

Slow rivers are manmade streams which are level and have a slow stream, boosted by pumps. The 2-3 mph stream will generally vary in width from 8-14 feet and range in depth from 27-48 inches. Guests float along the river on floatation devices which are generally innertubes. Guests must always sit or recline while floating on the river.

Safety depends upon an attentive guarding staff working within the 10/20 rule (a guard must be able to scan his or her designated area every 10 seconds and must be able to respond to a person in distress within 20 seconds).

Access to and egress from the rivers must be fenced sufficiently to clearly define entry and exit points and the fence must be located so guards have full access to the river perimeter.

The river must meet all standard operating procedures including depth markers and identification of discontinuities in the side walls and floors where booster nozzle may be located.

Wave Pools

Wave pools can vary widely in type and style. The most dominant is the wave action pool which produces one or more wave patterns, usually having a crown to valley displacement of less than 3-4 feet. Typically, 75% of the pool surface is less than 4 feet deep. Guards must closely adhere to the 10/20 rule (a guard must be able to scan his or hers designated area every 10 seconds and respond to a person in distress within 20 seconds) and must aggressively control horseplay among the guests. Generally, the waves are on for 10-12 minutes and off for a similar amount of time simply because the action is very tiring, and guests tend not to leave the water to rest unless the waves stop.

Tsunami pools generate a single large wave (up to 8 feet high) on a slower frequency than the action pools. A single wave passes through the pool every 2-10 minutes. This type pool unlike the action pool has characteristic secondary wave patterns, draughts, cross currents and back flows which are seemingly random in pattern and continue for several seconds to a couple of minutes after the main wave passes.

Access to both types of pools should be restricted to the “zero depth end” only and the balance of the pool perimeter should be clearly marked or fenced to prevent guest access. Guest are not permitted to hang on sidewall ladders which should be marked for emergency use only.

Activity Pools

Activity pools for small children feature a random array of play attractions in water which ranges from very shallow to several feet in depth. These play attractions must be supervised and controlled by staff and parents. Signs and attendant direction should require parents to supervise the activity of their children.

Adult pools may be deeper in depth with some having water depths to 13 feet if the attractions drop the guests any significant distance above the water. Diving is never permitted but jumping feet first or bring ejected feet first is permissible with the deeper water depths. As with the kid’s pool, close supervision is required. Cable drop rides, canon ball slides, rock jumps, swing out slides and similar devices require supervised dispatch and close monitoring of the catch areas.

In addition to the 10/20 rule it is important to verify the total number of lifeguards on duty. Lifeguard chairs should be placed to minimize glare on the “after and in” position to give complete visual coverage of the pool. The number of lifeguard chairs required is:

Lifeguard Chairs	Pool Surface Area (sq.ft.)
0	1000 or less
1	1001-2000
2	2001-4000
3	4001-6000
4	6001-8000
5	8001-10000
Note: Over 10000sq. ft. the ratio is 1 chair for every 2000 sq. ft. of pool surface area.	

The four main areas of concern when inspecting a water park:

- Inspection of the equipment and attractions
- Check of the operational and training
- procedures Conduct of the staff and guests
- during operation Signage

Water Quality

The quality of the water is important in all types of attractions where there is the possibility of coming into contact with water. This does not mean just wading in a pool or sliding down a tube. Attractions where patrons ride in a boat or similar vehicle is a good example. These types of attractions may have a random water fall that the passenger carrier may pass under or even jets of water that spray onto the patrons. They may also have hills that the patrons go down causing a big splash.

Another type of attraction is Water Play areas. These are areas where mostly small children walk around in near zero depth water, but water is being sprayed from all over the attraction. Some of these attractions may have a large bucket that fills up and then dumps every few minutes.

Whichever type of attraction it is, water quality needs to be checked regularly. Many types of diseases may be present in the water and cannot be seen. There are different ways of controlling the water quality and this is regulated by the health department.

The use of chemicals is widely used in waterparks. These chemicals can be more dangerous than the actual diseases if they are not handled and stored properly. Some of these are Chlorine, Hydrogen Peroxide, Ammonia, and Potassium Cyanide. There are regulations by several entities on these chemicals. This can be the Health Department, DHS (Department of Homeland

Security), OSHA, and/or other state and local agencies. It is important as the inspector to know the guidelines and requirements.

Material Safety Data Sheets (MSDS) are documents that inspectors need to be aware of. These documents contain information on the potential hazards and how to work safely with the chemical product. It is imperative that any person involved with the handling of chemicals be familiar with the MSDS for the chemicals and how to obtain this information on site.

Personal Protective Equipment (PPE) should be worn as described in the chemicals MSDS. Some chemicals may only require a certain type of glove. Others may require special gloves, glasses, full face protection and may even require the use of an oxygen mask while changing bottles. Always refer to the products MSDS to verify the uncertainty of what PPE is required.

Flow Rate

The water flow in a slide has an effect on the performance of the sliding surface. It is important to keep the Flow Rate within the manufacturers specifications. The amount of water flowing can be confusing. Once the slide surface is within the Flow Rate, increasing the water flow may cause riders to slow down and decreasing the water flow may cause them to speed up.

Irregular Flow Rates may be a sign of a problem in the water filtration system. Pump impellers needing replaced and clogged filters can cause Flow Rates to be out of spec. The Flow Rate and pressure need to be monitored regularly to help limit the amount of down time and system failure.

Slide Vehicles

Some slides and/or water attractions may use tubes or other types of vehicle for passengers to sit in while on the attraction. Each attraction shall use only the designated tube for that particular attraction. Some slides the manufacturer may only allow a single person tube and others a 2-person tube may be ok.

Air pressure on tubes is another important thing to check every day and sometimes throughout the day. Tube pressure can change as the sun hits the tubes and different parts of the day.

Tubes with improper pressure can cause the patron to go to fast, go to slow or even flip out of the tube. Tube handles or holding devices should be checked every day as well. It is important to use the proper tube and to ensure it is in good shape to be used.

Slide Material

There are different materials the waterslides are made from. Polyethylene and Fiberglass are 2 of the most common. Each type has its own advantages and disadvantages. Maintenance differs between the 2 and it's important to understand how to detect noticeable issues. The manufacturers manual will have checklists of the items needed checked daily.

Seams are very important and need to be closely monitored. A leaky seam can be an indication of many things. Could just be loose bolts on the flange or a sign that the sealant between the flanges needs replaced. Can also mean there is a crack in the gelcoat allowing water in. Once water enters past the gelcoat and wicks into the fibers, this can cause severe damage over time. The change in temperature causes the water to expand and contract causing the fiberglass to lose its structural ability and fail.

Seams must also be flush from one section to another. The upstream section may be 3/16" maximum higher to ensure a smooth transition. The lower section CANNOT be higher as this will cause a lateral edge which the patron could hit.

Inspection of other parts of the flume are just as important as the seams. There may be cracks or distortions in the gelcoat that can indicate an issue or even that something may have fallen and hit the slide. Knowing how to interpret these signs can help in diagnosing an issue and how to repair the slide.

Samples of Gel Coat Damage





5. Blisters — Osmotics
Small blisters — gel coat; large — laminate



6. Catalyst Drop Gassing
(can likely blister as in photo #4)

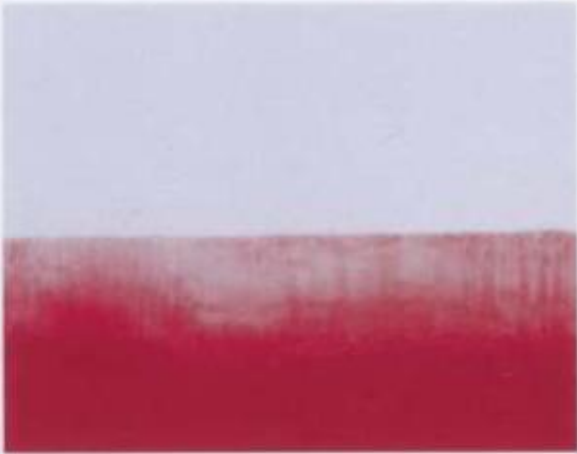

3. Bleeding



4. Blisters — caused by catalyst drop

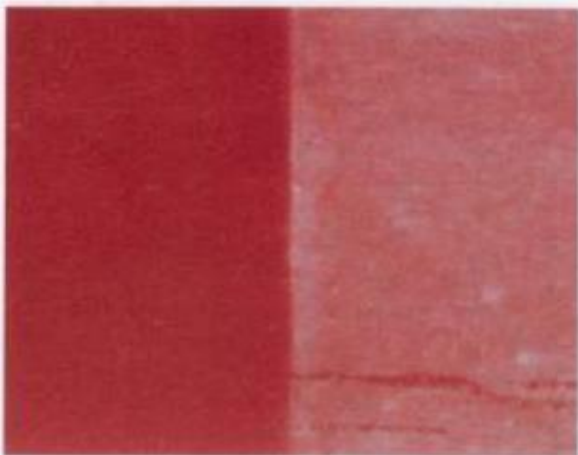

7. Chalking

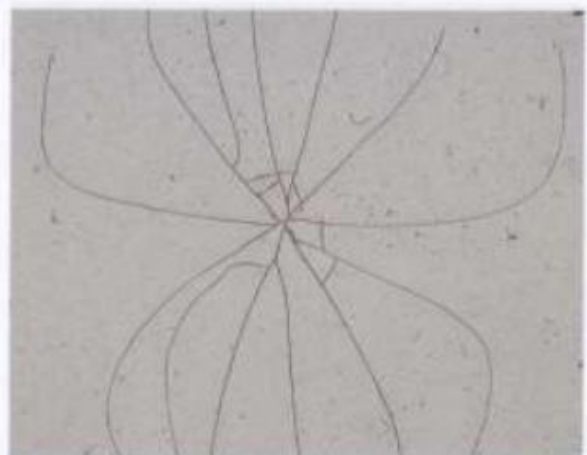

8. Cracks - reverse impact
(spider/star)

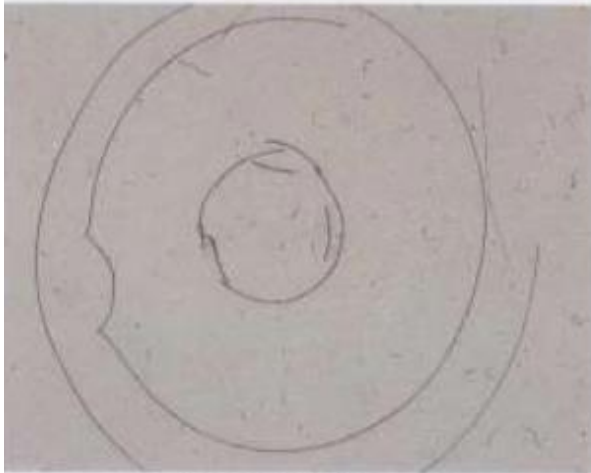

9. Cracks - frontal impact



10. Cracks - stress

Conclusion

This study guide is to be used as a starting point for review to take the inspector test for Water Attractions. This may also be a good document to read over periodically as a refresher.

The information given in this document is not everything needed to inspect water attractions thoroughly. It is the inspector's responsibility to research all pertinent information and adhere to the manufacturers requirements as well as all Authorities Having Jurisdiction (AHJ).

The following documents consist of contact information and important Regulation items. Also included is information for the Ride Approval process along with helpful checklist with items from the ASTM Standard as of December 15, 2020.

Contact Information

Joe Filoromo, Ride Safety Supervisor

Use this contact to contact for inspection, registration, certification issues and questions.

- Cell: (717) 215-4316
- Fax: (717) 425-7274
- Email: jfiloromo@pa.gov
- E-mail from Texts: Allows you to send things to E-Mail without waiting until you get to your computer. Send text messages and photos to E-mail by inputting jfiloromo@pa.gov in place of the telephone #.

Contact Joe by e-mail for:

- **Equipment Registration or renewal applications**
- **Inspector applications or renewal applications**
- **Inspector Test Study Material – specify which test**
- **Ride or attraction Operator Manual**
- **Accident Reporting Form**
- **Itinerary Report Form**
- **Copy of Regulations, Act, or Rider Responsibility Act**
- **Inquire about the status of your certification**
- **Assistance with video inspections**

ALWAYS BE SURE THAT THE E-MAIL ADDRESS THAT THE DEPARTMENT HAS ON FILE FOR OWNERS AND INSPECTORS IS ACCURATE.

Be advised that failure to file all required documents on time and accurately may result in penalty actions including fines and shut downs.

Minimum Documentation Required on Site

- **Inspection Affidavit**
- **Certificate of Insurance**
- **Daily Inspection Checklist**
- **Operator Training Documentation**
- **Maintenance Logs**
- **Manufacturers Owner Manual**
- **Registration Plate with "Current year's sticker"**

INSURANCE REQUIREMENTS

- The Insurance Provider, (Insurance Co.) must file a "Certificate of Insurance" in Harrisburg before the owner may open or operate Amusements Rides or Attractions to the public in Pennsylvania.
- Certificates received from the Owner are not acceptable.
- The Provider must list the following as Certificate Holder:
Pennsylvania Department of Agriculture
Amusement Ride Safety Division
2301 N. Cameron Street
Harrisburg, PA 17110-9408
- It is the owner's responsibility to make sure that the provider sends the required information to the Department before opening.

ITINERARY REQUIREMENTS

- Itineraries are due at the time of registration or 15 Days prior to opening to the public and before completion of the Inspection Affidavit.
- Itineraries received less than 15 days in advance will be occasionally accepted as needed by E-Mail at jfiloromo@pa.gov or Faxed directly to Joe at 717-425-7274.
- Rental Companies must register an itinerary for every rental in advance of the event and before inspection.
- Inspections for Rentals at private homes are due monthly within 30 days prior to the rental.

The easiest and preferred way for an owner to submit Itineraries is to input them online using your username and password.

You may contact jfiloromo@pa.gov for a username and password if necessary.

INSPECTION AFFIDAVIT REQUIREMENTS

All Inspection affidavits are good for up to 30 days or until the ride is moved, so Permanent location inspections are normally due monthly and Traveling Show inspections are normally due after each set-up.

- **Inspection affidavits MUST be completed prior to opening rides to the public.**
- Inspection Affidavits that are not input directly into the on-line system must be postmarked or sent (Online, E-mail or Fax) within 48 hours of the inspection.
- The Inspection Affidavit must list the name of the Owner Company as it is registered with the Department.
- The Inspection Affidavit must be signed and dated by the inspector performing the inspection if not inputting online.

The easiest and preferred way for a Certified Inspector to submit Inspection Affidavits is to input them online using your username and password. Entering your Inspection Affidavit online verifies that you performed the inspection as required by the regulations.

Certified Inspectors may contact jfiloromo@pa.gov for a username and password if necessary. ³²

RIDE APPROVAL INFORMATION

DIVISION OF AMUSEMENT RIDE SAFETY

To: Amusement Ride Owners and Manufacturers

It is the intent of this letter to advise you of the requirements for Ride Approval for use of a ride type in Pennsylvania.

In accordance with the Pennsylvania Ride Inspection Act Chapter 139 issued under Pa Code 7, all Amusement Rides and Attractions are required to be approved for use prior to their operation in the Commonwealth. The approval is required for all newly designed and manufactured rides as well as those that have not been previously operated in the Commonwealth. Any ride or attraction not recognized as an **"Approved Type"** is not permitted nor allowed to operate until accepted by this Department.

The Department requires documented verification from a Registered Professional Engineer, licensed in the Commonwealth of Pennsylvania per Chapter 37 issued under section 4 of the Engineer, Land Surveyor and Geologist Registration Law (63 P.S. § 151) before the Ride or Attraction will be considered for acceptance. Briefly, the Professional Engineer must affix the engineer's seal and certify to the following criteria:

- The Ride or Attraction has been designed and manufactured in conformance with the ASTM Standards on Amusement Rides and Devices pursuant to the ASTM F-24 committee.
- The ride is manufactured in conformance with the Pennsylvania Regulations Chapter 139 Pa. Code 7

The Ride/Attraction submission shall also include:

- (1) An Owner's Manual that is specific for the ride.
- (2) An overall photograph of the Ride or Attraction.
- (3) An owner's registration form.
- (4) Inspection Check List

If rides or attractions are found to be operating that have not been approved or not approved by the Department, penalty actions may be issued.

If you have any questions regarding the Pennsylvania Ride Inspection Act requirements, please do not hesitate to contact Joe Filoromo at jfiloromo@pa.gov or 717-215-4316.

Thank You,



Joseph G. Filoromo, Supervisor
Amusement Ride Safety Division

Does the attraction meet the following items as referenced in the ASTM Water Slide Standard F2376 and Pa Regulations 7 Pa Code Chapter 139?

	Yes	N/A	Reason for N/A or Comment
1. Slide and/or attraction adheres to F770 for Operations as noted in Section 2. Referenced Materials.			
2. Strength of steel structure is designed in accordance with current AISC, ASCE standards, or equivalent national standards. F2376 Section 7.7			
3. Strength of timber structure is designed in accordance with current USDA-72, ASCE standards, or equivalent national standards. F2376 Section 7.8			
4. Strength of concrete structure is designed in accordance with current ACI-318 or equivalent national standards. F2376 Section 7.9			
5. Slide access has proper guardrails. Deck and stairs are slip-resistant and self-draining. F2376 Section 8.2			
6. Flume cross-section shape is configured to contain the rider or vehicle, or both, under all reasonable operating conditions. F2376 Section 8.3.1			
7. Flume riser parts shall be transitioned from sections without flume risers to sections with flume risers with a maximum angle of 45 degrees from the horizontal. F2376 Section 8.3.3.1			
8. Where a cover, a tube entrance, or a flume riser is fitted other than at the beginning of the slide, the sides of the slide shall have a smooth transition from horizontal to vertical. Max angle of transition will be 45 degrees. The inside height of the entrance to the cover or flume riser shall be at least 48 in. F2376 Section 8.3.3.2			
9. The manufacturer has determined the flow rate and set a fixed range of acceptability for the installation. F2376 Section 8.5.1			
10. Flow meters, calibrated means of flow measurement, or markers indicating proper operational water flow/level are provided for			

each flume. F2376 Section 8.5.3			
11. Run out section is designed to contain, decelerate, and stop riders to allow them to exit the slide. F2376 Section 8.6.1			
12. A weir or other device shall regulate the water level in the run out to the correct level given correct flow rate for the ride. F2376 Section 8.6.2			
13. To facilitate proper deceleration, a marker shall be provided to indicate the operational water level in the run out, which the slide attendant/lifeguard may verify prior to allowing the next rider entry to the slide. F2376 Section 8.6.3			
14. The exit path for riders shall not cross with the landing zone of other slides. F2376 Section 8.7.2			
15. Water slides entering a landing pool shall have a landing pool of sufficient length to decelerate and stop riders and minimize the potential for contact with the pool wall or stationary objects. F2376 Section 8.7.3			
16. Water slides classified as speed slides (rider velocity over 25 ft/s) will require additional pool length. F2376 Section 8.7.3			
17. Pool depth in the landing zone for water slides for persons over 48 in. tall shall have a minimum pool depth of 3 ft. F2376 Section 8.7.4			
18. Body slides entering a landing pool shall have a minimum distance between the inside of the widest part of the flume riding surface and the closest pool wall of 5 ft. F2376 Section 8.7.8.1			
19. Tube slides entering a landing pool shall have a minimum distance between the inside of the widest part of the flume riding surface and the closest pool wall of 4.5 ft. F2376 Section 8.7.9.1			
20. Openings may be provided in flume surfaces for introduction of water, drains, special effects, light, and other similar purposes. All edges in openings within reach of riders shall be smooth with a minimum radius of 1/8 in. F2376 Section 8.8.1			

	Yes	N/A	Reason for N/A or Comment
21. Slide paths shall be designed so riders in seated or prone (laying face down) positions do not experience greater than 2 Gs acceleration from gravity and centrifugal acceleration vectors added together. This limit may be increased to 3 Gs if the duration is less than 1 second. F2376 Section 8.10.1			
22. Slide paths shall be designed so that riders in supine (laying face up) positions do not experience greater than 3 Gs acceleration from gravity and centripetal acceleration vectors added together. F2376 Section 8.10.2			
23. The manufacturer of a new slide or major modification to an existing slide shall specify prior to commissioning or re-certification, test or inspection procedures, or both, in compliance with Guide F846 and Practice F1193. F2375 Section 9.1			
24. Manufacture has recommendations for the clearance envelope. PA REG 139.43.8			
25. Manufacturers manual includes instructions for operation requirements and procedures. PA REG 139.76 and ASTM F770			

***The above items are key items to be verified. This does not exclude any other section of 7 Pa Code Chapter 139 and/or ASTM F24 Standards. ***

**PENNSYLVANIA DEPARTMENT OF AGRICULTURE
AMUSEMENT RIDE AND ATTRACTIONS
SAFETY DIVISION**

WATER SLIDE AND WATER PARK INSPECTION

COMPANY NAME _____ **ATTRACTION** _____
ADDRESS _____ **ID NUMBER** _____

CODE: (S) Satisfactory (N) Non-Satisfactory (C) Corrected (X) Does Not Apply

LOCATION & INSTALLATION

	S	N	C	X
1. Free from adjacent hazards & interference (proper barrier) -F2376 7.0 -----				
2. In level position on solid ground or pavement foundations -----				
3. Proper hand holds -----				
4. Properly anchored, braced & guyed—F2376 7.0-----				
5. Motors, belts & cables guarded from the public -----				
6. Stairs & walkways in safe & secure condition -F2376 8.2-----				
7. Proper fencing & railings (wave pools 42" minimum) F2376 8.2-----				
8. Steps & ladders -F2376 8.2.3—F2376 8.2-----				
9. Fire extinguishers – number, size & location -----				
10. Free of unguarded pinch points & slippery surfaces -----				

STRUCTURAL INTEGRITY

11. Assembled in correct manner—F2376 -----				
12. Free of cracks & excessive wear—F237 -----				
13. Properly bolted with correct grade bolts-----				
14. Chemical storage -----				

ELECTRICAL SAFETY

15. Properly grounded -----				
16. Boxes covered -----				
17. Lighting guarded -----				
18. Communications system -----				

OPERATIONS

19. Proper rest periods -----				
20. Number of guards -----				
21. Height requirements-F2376 12.4.3.2 -----				
22. Safety requirements -----				
23. Safety equipment -----				
24. Signal systems-F2376 12.2.1.3 -----				
25. Proper guard training-F2376 12.2 -----				
26. Water clarity-F2376 12.6 -----				

MISCELLANEOUS SAFETY ITEMS

27. P.F.D.'s available at no charge -----				
28. Test kit on hand -----				
29. Proper warning signs EXIT & ENTRANCE & RULES—F237612.4-----				
30. Maint.log/license available/water test documentation—F237612.7-----				
31. Chlorine residual (0.4) -----				
32. Other (PH test-7.2 to 8.0) -----				

COMMENTS _____

SIGNATURE _____
DATE _____